

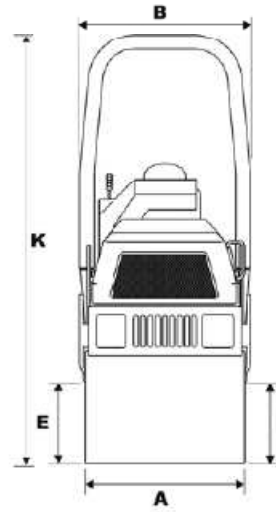

TEREX® TV1200

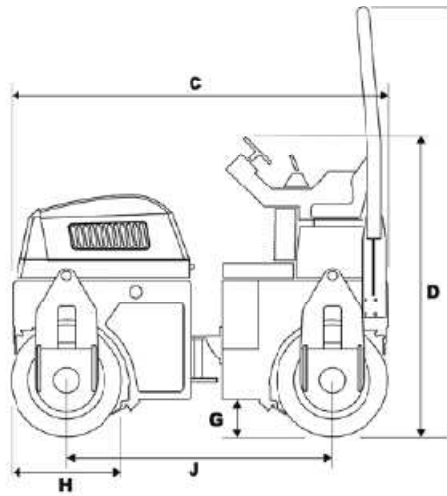

	TV1200
A - Drum Width (mm)	1200
B - Overall Width (mm)	1270
C - Overall Length (mm)	2375
D - Height to Top of Steering Wheel (mm - Transport Height)	1940
E - Curb Clearance - Right (mm)	555
F - Curb Clearance - Left (mm)	490
G - Ground Clearance (mm)	230
H - Drum Diameter (mm)	700
J - Wheelbase (mm)	1675
K - Height to Top of ROPS frame (mm)	2650
Overhang - Left / Right (mm)	35 / 35

Steering

	TV1200
Steering Type	Centrepoint Articulation - Double acting (via single hydraulic ram)
Inside Turn Radius (mm)	2525
Outside Turn Radius (mm)	3795
Frame Articulation (degrees)	30
Frame Oscillation (degrees)	15

Capacities

	TV1200
Hydraulic Tank Capacity (litres)	44
Fuel Tank Capacity (litres)	44
Water Tank Capacity (litres)	180

WINNER PLANT

SUSSEX: 01903 230700

SURREY: 01483 456789

EMAIL: SALES@WINNERPLANT.CO.UK



TEREX® TV1200

Performance	
	TV1200
Total Static Basic Weight (kg)	2740
Operating Weight (kg) CECE	2925
Static Linear load (kg/cm)	12.18
Frequency - Hz (VPM)	48/
Amplitude (mm)	0.6
Centrifugal Force (kN)	48/56 (2880/3360)
Gradeability (% - vibration on)	30
Gradeability (% - vibration off)	40
Drum Shell Thickness (mm)	13.0

Engine & Drive	
	TV1200
Engine Make	Kubota
Engine Model	D1703-M
Cylinders	3
Displacement (cc)	1647
Cooling	Water
Power - kW (HP)	24.5 (32.83)
Operating Speed	2300/2800
Fuel Type	Diesel
Drive (both drums)	Hydrostatic
Travel Speed (kph)	10

Watering System	
	TV1200
Tank Capacity (litres)	180

Electrical System	
	TV1200
Battery (volts)	12V DC
Alternator (amp)	55

WINNER PLANT

SUSSEX: 01903 230700

SURREY: 01483 456789

EMAIL: SALES@WINNERPLANT.CO.UK