

**neuson®****1001****Capacity**

Max. safe load	1000 kg
Unladen weight	1215 kg
Skip - struck	415 l
- heaped	525 l
- water level	275 l

Engine

Make	Yanmar
Type	3TNV76 3-cyl, watercooled
Output (Iso 3046/1)	18,9 (23,1) kw (hp)
Revolution	3000 min ⁻¹
Displacement	1116 ccm
Emission	acc. 97/68/EG

Drive characteristics

Speed	0 - 16 km/h
Steering angle	+/- 33 °
Oscillation	+/- 15 °
Turning radius outside	3200 mm
Gradeability	45 %

Transmission

Final Drive	hydr. automotive, TWIN-LOCK permanent 4 wheel drive, electro-hydraulic direct control
Steering	hydrostatic center-pivot steering (load sensing)
Tyres	10.00/75x15 [6.00-16] 8 Ply [6 Ply] Traction profile
Working brake	Hydrostatic
Parking brake	Wet disc in rear motors

Hydraulic System

Drive pump	axial piston pump	84 l/min
- flowrate		360 bar
- oper. press.		
Working pump	gear pump	25 l/min
- flowrate		170 bar
- oper. press.		

Tank capacity

Diesel	15 l
Hydraulic	20 l

Electric

Voltage	12 V
Battery	50 Ah
Alternator	20 A
Starter	1,2 kw

Noise Emission

Noise Level LWA (acc. 2000/14/EC)	101 dB(A)
-----------------------------------	-----------

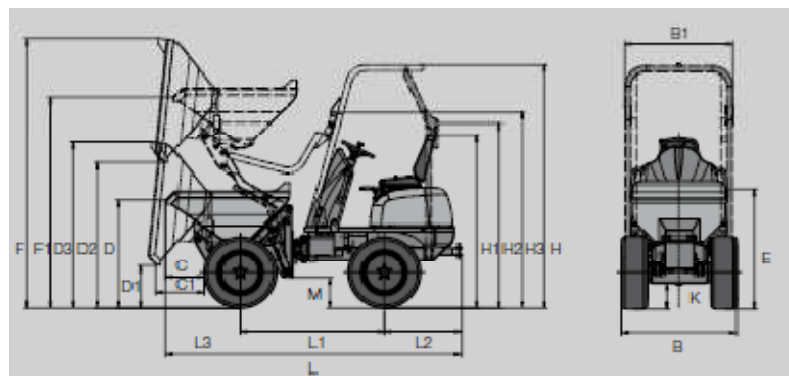

B	1180 mm
B1	1130 mm
B2	-
C	385 mm
C1	510 mm
D	1160 mm
D1	465 mm
D2	1560 mm
D3	1770 mm
E	1230 mm
F	2860 mm
F1	2250 mm
G	-

H	2580 mm
H1	1850 mm
H2	1960 mm
H3	2080 mm
J	-
K	270 mm
L	3080 mm
L1	1500 mm
L2	810 mm
L3	770 mm
M	327 mm

WINNER PLANT

SUSSEX: 01903 230700

SURREY: 01483 456789

EMAIL: SALES@WINNERPLANT.CO.UK